

lation with maximum safety factor. There are many unique features as well as options available on these sleeves. Unique to these sleeves are the following

Separate Body and Tapping Gland (outlet) - By separating the outlet gland from the sleeve body the sleeve reinforces the pipe prior to removal of the critical prestress wire from the outlet area.

Broad Cross Section Gasket - The 7/8" wide gasket with a hydromechanical lip provides a broad sealing surface which produces an initial seal that increases with increases in line pressure. The broad, flat gasket is very advantageous for sealing on beveled cylinder welds.

Gusseted Pressure Plate - The gusseted pressure plate eliminates problems caused by flexing of the cylinder or tapping sleeve pressure plate. This grooved plate is contoured to fit the cylinder and retains the broad profile gasket to provide an extra margin of safety at this critical point.

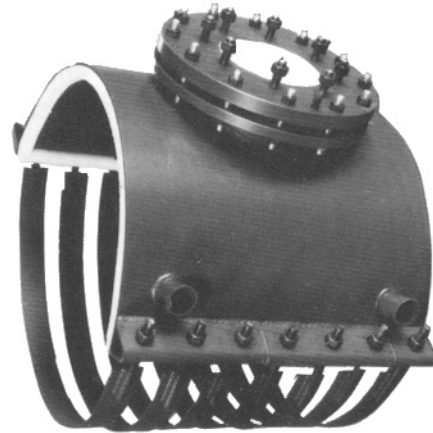

Combination Gland/Draw Flange - The combination gland/draw flange on 4" - 12" outlet sizes facilitates tapping with a 25" travel tapping machine. Larger outlets utilize separate flanges for each function to make bolt take-up on large flanges more accessible.

Load Bearing Set Screws - The IFT 415 Tapping Sleeve is furnished with load bearing set screws on the gland flange that are tightened after the gland is installed. These set screws tighten against the sleeve draw flange, transferring any load on the outlet away from the steel cylinder and onto the sleeve.

Grout Seal Assembly - Type I 415 Tapping Sleeve, the standard sleeve, is furnished with straps and a grout seal assembly under the sleeve. These two design features facilitate fitting oversize, undersize and out-of-round pipe by providing the means to pour cement grout into a cavity to make a perfect sleeve fit. This feature is in accordance with AWWA M-9 Manual as recommended by the manufacturers of concrete pressure pipe. Epoxy coated sleeves and sleeves with a solid back sit directly on the pipe, precluding the use of the grout seal assembly.

Epoxy Coated Waterway - The tapping sleeve's waterway is fusion applied epoxy coated to provide a quality connection protected against corrosion in the critical waterway

HOW TO ORDER

For pricing and engineering, the following information must be furnished:

- Type of pipe (also manufacturer and class if known)
- Type of sleeve
- Outside diameter of pipe and cylinder O.D.
- Line content and pressure
- Outlet size (on outlets 14" and larger furnish manufacturer of valve and cutter size)
- Any special requirements or options.

415 Tapping Sleeve for Concrete Steel Cylinder Pipe

Many agencies have special requirements which are modifications of our standard design. 2LBin's manufacturing flexibility makes it possible for us to offer a great many modifications without delay in product availability. Some of the more popular options on these sleeves are:

A solid back half in lieu of straps (Type II) for Pretension Concrete Cylinder Pipe.
Entire sleeve and outlet epoxy coated with stainless steel straps.
Different locations of the grouting holes.

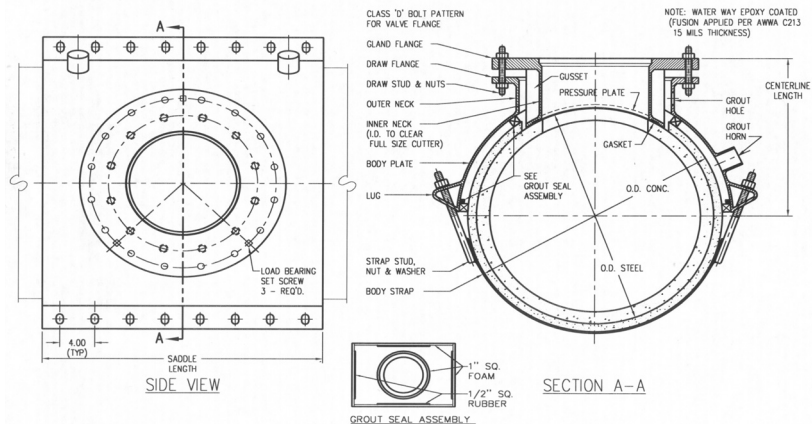

415 Tapping Sleeve for Concrete Steel Cylinder Pipe - Typical Specification

Tapping Sleeves for Concrete Steel Cylinder Pipe shall be in accordance with AWWA Manual M-9. They shall also meet AWWA C-301 and C-303 Standards pertaining to design, manufacturing quality tests and welders qualifications. Manufacturers shall have manufactured this type of tapping sleeve for a minimum of ten (10) years.

The sleeves shall have a separate gland which permits installation of the sleeve prior to the cutting of the prestress wires. The gland shall have a fusion epoxy coated (per AWWA C-213) waterway, and a minimum 7/8" wide hydromechanical gasket set in a retaining machined groove of a pressure plate. For outlet sizes 14" and larger, the gasket groove must be consistently positioned about throat of tapping waterway. Inside diameter of the gasket groove must be set back a minimum of 1" from the waterway to allow dispersal of forces generated by gasket compression. Gasket grooves machined in a circle and formed to an elliptical shape will not be an accepted equal. The pressure plate shall be gusseted to the draw flange to eliminate flexing. The gland shall be equipped with load bearing set screws to protect the cylinder. Sleeves shall be furnished with grouting seals and grout horns to facilitate filling the space between the sleeve and the pipe. Tapping sleeves shall be ANSI/NSF Standard 61 Certified. Tapping Sleeves shall be 2LBin.415 Tapping Sleeve or approved equal.

415 Tapping Sleeve for Concrete Steel Cylinder Pipe - Material Specification

- BODY:** ASTM 283 Grade C or ASTM A-36 Steel
- FLANGE:** Combination flange with ANSI 150 lb. Drilling, recessed for tapping valve MSS-SP60
- GASKET:** Compounded for use with water, salt solutions, mild acids, bases and sewage.
- BOLTS:** Corrosion resistant, high strength low alloy (AWWA C-111, ANSI A21.11). Optional Stainless Steel, 18-8 Type 304.
- FINISH:** Heavy coat of corrosion resistant primer on sleeve, gland and straps. Waterway of gland is epoxy coated (fusion applied per AWWA C-213). Optional Fusion Epoxy Coating on entire sleeve.

2LBin products Tapping Sleeves meet or exceed the ANSI/AWWA C-223 and the MSS-SP 124 Standards as applicable.

2LBin products recommends a template of the outside diameter of the pipe surface on all taps with an outlet of 24" or larger, on all taps where the outlet is more than 60% of the pipe size, on pipe which out-of-roundness is suspected and on high-pressure taps where the fit of the sleeve is critical to the high pressure performance. Instructions for this procedure are available from 2LBin upon request.