

## Resilient Seated Solid Wedge Gate Valve - Series 6800

AWWA C509 & C515 ▪ NRS Type ▪ FL x FL ▪ Sizes 2" - 16"

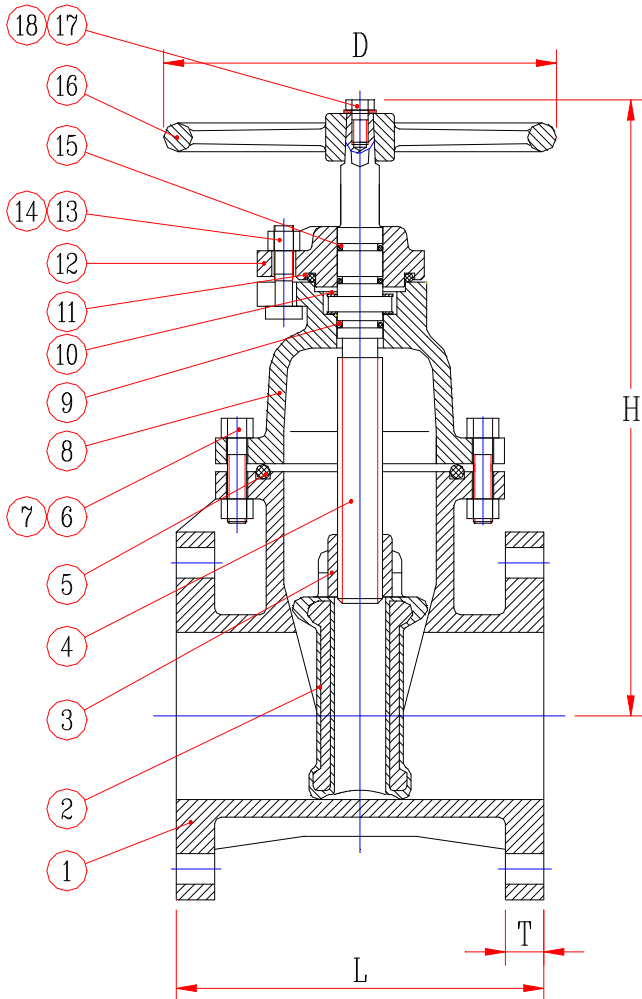

No	Part Name	Materials
1	Body	Ductile Iron ASTM A536 65-45-12
2	Wedge	Ductile Iron EPDM Encapsulated
3	Stem Nut	Bronze ASTM B62 Low Zinc
4	Stem	Stainless Steel
5	O-Ring Gasket	EPDM
6	Bolts	Stainless Steel AISI 304
7	Nuts	Stainless Steel AISI 304
8	Bonnet	Ductile Iron ASTM A536 65-45-12
9	O-Ring	EPDM
10	Washer	Copper ASTM B16
11	O-Ring	EPDM
12	Gland	Ductile Iron ASTM A536 65-45-12
13	Bolts	Stainless Steel AISI 304
14	Nuts	Stainless Steel AISI 304
15	O-Ring	EPDM
16	Handwheel	Ductile Iron ASTM A536 65-45-12
17	Bolts	Stainless Steel AISI 304
18	Washers	Stainless Steel AISI 304

### Standard Features:

- Design and Materials Exceed AWWA C509, C515 & C550.
- Flanges Conform to ANSI B16.1, Class 150.
- 4"-12", Available, with ANSI B16.2, Class 250, Flanges.
- Ductile Iron: Body, Bonnet, Wedge, and Gland.
- Fusion Bonded Epoxy Coatings ANSINSF61  
12 Mils In and Out per AWWA C550.\*
- Stainless Steel Nuts, Bolts, and Washers.
- Stainless Steel Stem
- Ductile Iron, EPDM Encapsulated Wedge .
- EPDM Gaskets and O-Rings.
- 250 PSI Working Pressure.
- Working Temperature: EPDM 33°F to 248°F.
- 2" Ductile Iron AWWA Nut, Ductile Iron Handwheel  
or Automatic Actuators Available.

### Dimensions:

Size	Model	L	H	D	T	Approx. Weight
2"	6802	7"	9 <sup>7</sup> / <sub>8</sub> "	7 <sup>1</sup> / <sub>4</sub> "	<sup>5</sup> / <sub>8</sub> "	49#
2 <sup>1</sup> / <sub>2</sub> "	6825	7 <sup>1</sup> / <sub>2</sub> "	11"	7 <sup>1</sup> / <sub>4</sub> "	<sup>3</sup> / <sub>4</sub> "	51#
3"	6803	8"	13 <sup>1</sup> / <sub>2</sub> "	10"	<sup>3</sup> / <sub>4</sub> "	65#
4"	6804	9"	15 <sup>1</sup> / <sub>2</sub> "	10"	1"	99#
5"	6805	10"	16 <sup>1</sup> / <sub>2</sub> "	12"	1"	143#
6"	6806	10 <sup>1</sup> / <sub>2</sub> "	18 <sup>1</sup> / <sub>4</sub> "	12"	1"	154#
8"	6808	11 <sup>1</sup> / <sub>2</sub> "	22 <sup>1</sup> / <sub>2</sub> "	14"	1 <sup>1</sup> / <sub>8</sub> "	229#
10"	6810	13"	25 <sup>1</sup> / <sub>2</sub> "	17 <sup>1</sup> / <sub>2</sub> "	1 <sup>1</sup> / <sub>4</sub> "	372#
12"	6812	14"	30 <sup>1</sup> / <sub>2</sub> "	17 <sup>1</sup> / <sub>2</sub> "	1 <sup>1</sup> / <sub>4</sub> "	588#
14"	6814	15"	34"	21"	1 <sup>3</sup> / <sub>8</sub> "	756#
16"	6816	16"	40 <sup>3</sup> / <sub>8</sub> "	21"	1 <sup>1</sup> / <sub>2</sub> "	1,212#